



# Power-Gold™ Finish

Industry Standard Yellow Dichromate

## Power-Gold™

Power-Gold is a yellow dichromate finish applied over an electro-galvanized zinc plating, and is totally compatible with the aesthetics and performance of yellow dichromate finishes used on other brands of metal framing. It is ideal for retrofit to projects and end-uses that have standardized on the "Gold" finish.

A .5 mil electro-galvanized zinc plate is applied with a cohesive molecular bond to the steel base metal, in compliance with the ASTM B633 standard. Yellow Dichromate is applied over the zinc and results in a gold appearance

which acts as a nonporous barrier sealant.

This finish provides a surface which inhibits early white rust and can act as a primer surface for painting.

It should be noted that the long-term corrosion resistance of zinc is directly proportional to thickness. Industrial grade finishes are available with heavier zinc finishes for ultimate long-term protection. See the reverse side for Power-Strut finishes that meet

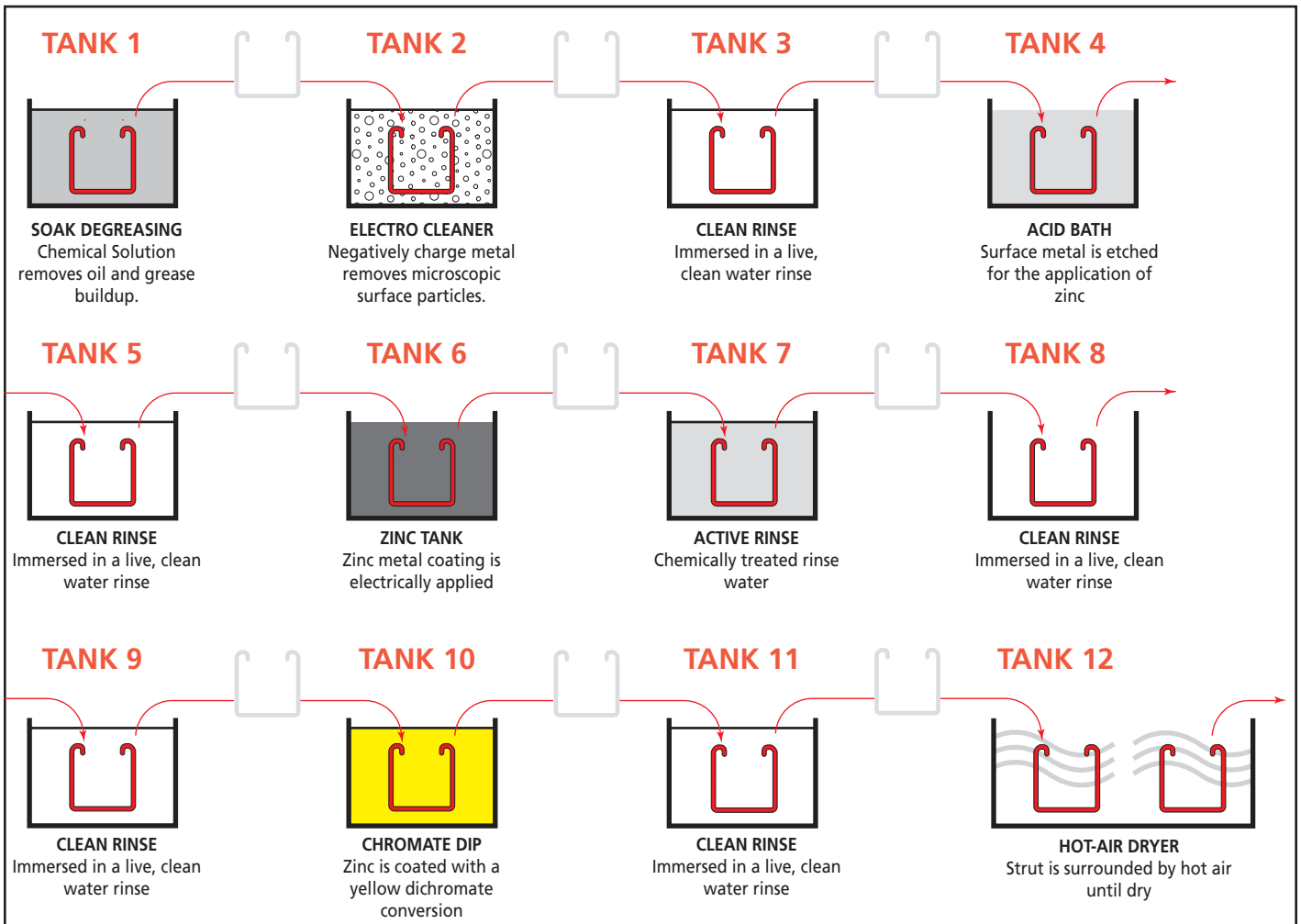
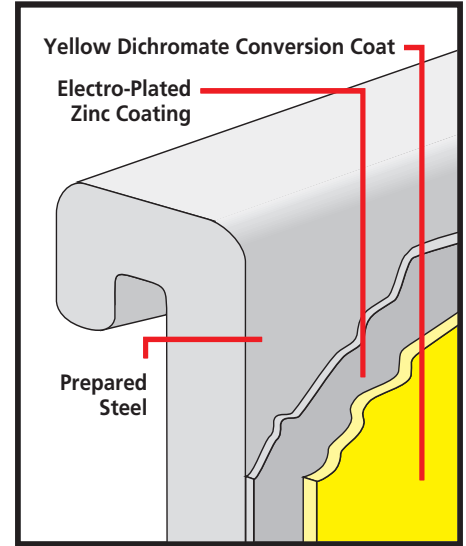

# Other Power-Strut Finishes



## Pre-Galvanized

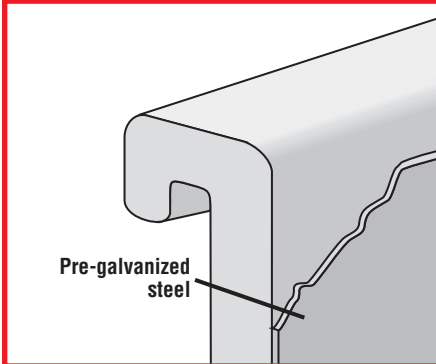

**PRE-GALVANIZED** - Material (steel strip) is coated with zinc by hot-dip process prior to roll-forming or press operations. The zinc coating weight is G90 conforming to ASTM Specification A653 GR 33.

## Hot Dip Galvanized

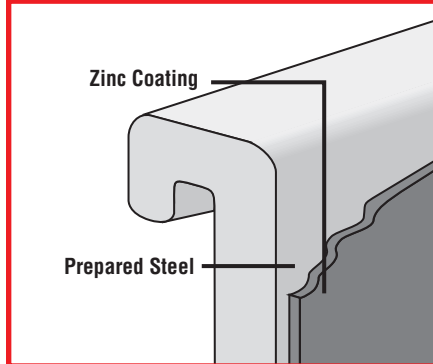

**HOT-DIPPED GALVANIZED** - Material is coated with zinc after being roll-formed or after all manufacturing operations are completed, conforming to ASTM specification No. A123 or A153.

## Electro-Galvanized

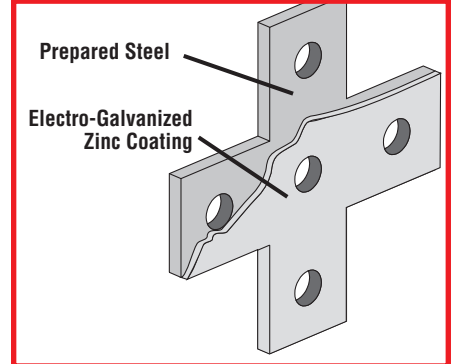

**ELECTRO-GALVANIZED**- Fittings and hardware are coated with zinc electrolytically to commercial standards (ASTM - B633 Type III C1).

## Stainless Steel

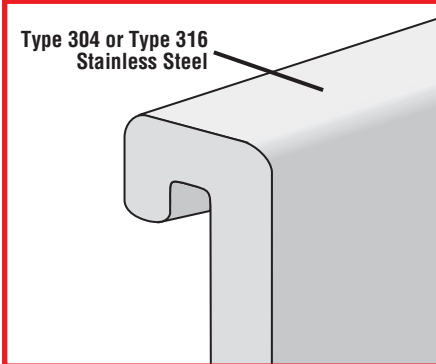

**STAINLESS STEEL** - Material in accordance with ASTM A 240 (Type 304 or type 316).

## Plain

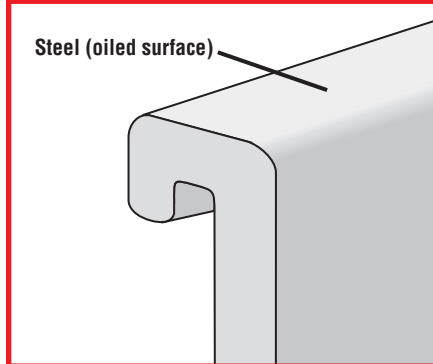

**PLAIN** - Plain finish designation means that the channel retains the oiled surface applied to the raw steel during the rolling process. The fittings have the original oiled surface of the bar-stock material.

## POWER-GREEN®

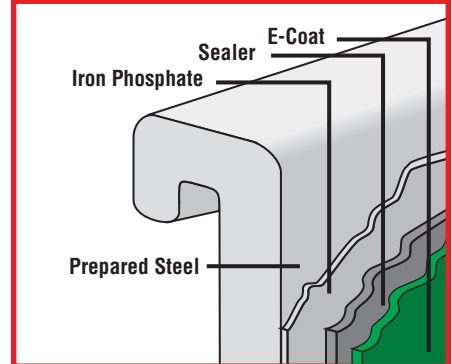

**POWER-GREEN®** - Channel and parts are cleaned and phosphated. Immediately afterward, a uniform coat of rust-inhibiting acrylic enamel paint is applied by electro-deposition and thoroughly baked.

## Aluminum

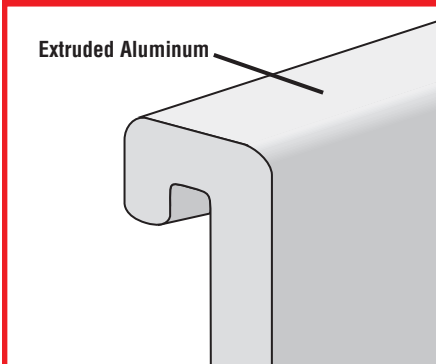

**ALUMINUM** - Extruded aluminum (ASTM B221 Type 6063-T6)

## COMPARISON OF ZINC GALVANIZED FINISHES

Finish	Zinc Thickness
Hot Dip Galvanized	2.6 MIL
Pregalvanized	.75 MIL
Electro-Galvanized	.2 to .5 MIL



Telephone: 800-882-5543  
www.atcelectrical.com

**tyco** / Electrical & Metal Products